

OVERALL DIMENSIONS

MACHINE	A	B1	B2	C	D	E	F	G	H	I	J	K	L	M
VM22	94 2388	125 3175	---	8 203	120 3048	39 991	38 965	38 965	39 991	70 1778	50 1270	45 1143	12 305	15 381
VM25	104 2642	144 3658	192 4877	8 203	120 3048	39 991	38 965	38 965	32 813	81 2058	50 1270	45 1143	2 51	9 229
VM30	104 2642	144 3658	192 4877	8 203	120 3048	39 991	38 965	38 965	41 1041	81 2058	50 1270	45 1143	2 51	12 305

NOTES:

- 1: FOR VM MACHINES WITH CONVEYOR:
ADD 35" (900mm) TO DIMENSION "L" FOR STANDARD TRAVEL.
ADD 44" (1100mm) TO DIMENSION "L" FOR EXTENDED TRAVEL.
- 2: ADD ONE INCH IN HEIGHT FOR EVERY INCH OF RISER ADDED.
- 3: DIMENSIONS LISTED IN ALL THE TABLES ARE INCHES OVER MILLIMETERS.
- 4: DIMENSIONS B1 & B2 INCLUDE 3" (75mm) EACH SIDE FOR DOOR HANDLES.

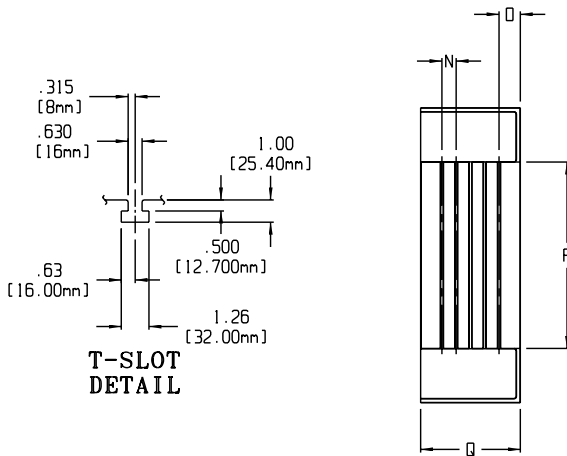

	VM22	VM25 & 30 STANDARD	VM25 & 30 EXTENDED
N	3.438 87.325	3.438 87.325	4.0 101.6
□	5.12 130.2	5.12 130.2	5.00 127
P	45 1143	55 1397	66 1676
□	24 609.6	24 609.6	26 660.4

VM22A-CURRENT, VM25F-CURRENT,
VM30J-CURRENT

CERTAIN INFORMATION CONTAINED HEREIN THE EXCLUSIVE PROPERTY OF MILLTRONICS MFG. CO. IT IS GIVEN IN CONFIDENCE AND IS NOT TO BE USED OR DISCLOSED TO OTHER THAN THE INTENDED RECIPIENT WITHOUT EXPRESSED WRITTEN CONSENT OF MILLTRONICS MFG. CO.

A	ADD 60" TRAVEL OPTION FOR VM25 & VM30	6084		3-24-06
REV.	DESCRIPTION	E.C.D. NO.	APP'D BY	DATE
		TITLE	SCALE	DWG No.
		VM22,25,30 MACHINE LAYOUT	45:1	6-11-018-059
APPLICATION		GENERAL PRODUCTS	DATE	SHEET NO.
			20 OCT 03	1 OF 1
			DRAWN BY	
			DAHLKE	